

FRONTENAC STORMWATER DESIGN MANUAL

for

CITY OF FRONTENAC, MISSOURI

City Hall
10555 Clayton Road
Frontenac, Missouri 63131
(314) 994-3200



EDM Incorporated
220 Mansion House Center
St. Louis, Missouri 63102



City of Frontenac
10555 Clayton Road
Frontenac, Missouri 63131

March 31, 2016

Table of Contents

1. Introduction..... 1

2. Standards..... 2

3. Applicability 3

4. Design Procedure for Best Management Practices 5

 4.1 Example 7

 4.2 Other Methods 8

 4.2.1 Sizing bio-retention based on its storage volume capacity 8

 4.2.2 Amended Soils 8

 4.2.3 Bio-Retention Retrofit..... 8

5. Design Requirements 10

 5.1 Bio-Retention Design..... 10

 5.2 Volume Storage and Controlled Release BMPs 11

 5.3 Underdrain Requirement..... 12

 5.4 Best Management Practice Discharge 12

 5.5 Drainage Area 13

 5.6 Drainage Structures..... 13

 5.7 Siltation Control..... 13

 5.8 Pop-ups 14

 5.9 Materials 14

6. Maintenance Agreements..... 15

Tables

Table 1. Stormwater Technology Table..... 2

Table 2. Extended Detention Volume Provided Formula..... 5

Table 3. Bio-Retention Sizing Formula and Required Coefficients 6

Table 4. Outfall Orifice Hole Sizing Equipments..... 12

Appendices

- Appendix 1 Site Plan Checklist
- Appendix 2 Example Details
- Appendix 3 Example Maintenance Agreements

1. Introduction

The City of Frontenac, Missouri lies in the Deer Creek watershed. This watershed is approximately 37 square miles of highly urbanized land cover. The City is a municipality of almost 3 square miles and is composed primarily of one-acre residential lots. Many of the subdivisions were built with minimal stormwater infrastructure. Since the turn of the century there has been a surge in residential redevelopment that is adding impervious area to the land cover. Runoff from this increase in impervious cover is taxing the limited stormwater infrastructure. The effects of this additional runoff have been felt both locally and regionally.

Locally, the increase of runoff is causing more frequent structure and yard flooding issues and more incidents of yard erosion to the adjacent neighbors of the redevelopment. Regionally, usable yard, adjacent to open channels, is being lost to erosion. It has been shown that the cross-sectional size of an open channel is directly proportional to the one-year peak flow. Thus an increase in the one-year peak flow will enlarge a natural channel causing loss of usable property.

In order to protect the citizens of Frontenac from these adverse impacts, the City adopted Chapter 506: Stormwater Regulations in the Municipal Code of the City of Frontenac. This code requires the use of best management practices to provide extended detention for a volume of water based on the one-year 24-hour rainfall depth of 2.5 inches.

Chapter 506 references this Stormwater Design Manual to assist with compliance of its provisions. This Stormwater Design Manual is meant to provide clear standards for engineers submitting plans for site redevelopment in order to expedite the permitting process.

Chapter 506 complies with the St. Louis County Phase II Stormwater Management Plan. This plan was written to comply with the National Pollution Discharge Elimination System Phase II Permit which is a result of the Clean Water Act. Frontenac is a co-permittee with MSD and 57 other municipalities in St. Louis County.

This manual identifies critical elements for site plan submission. It identifies a procedure for the design of stormwater best management practices (BMPs). It provides formulas and coefficients pertinent to the design of stormwater BMPs. It presents sample calculations and provides design restrictions and limitations. In addition, it:

- Illustrates the design procedure for Frontenac
- Provides required content for plan submittal
- Identifies landscaping requirements and options
- Identifies pre-treatment requirements and treatment requirements
- Provides design guidance for siltation control
- Provides information on acceptable and unacceptable materials for construction
- Provides frequently used formulas and coefficients
- Includes design examples for different types of BMPs
- Provides sample maintenance agreements and maintenance requirements

2. Standards

The following design standards, or their latest revision, shall be used unless they are in conflict with this Stormwater Design Manual, in which case the direction given here-in shall govern.

Landscape Guide for Stormwater Best Management Practices Design, St. Louis MO, MSD, May 2012 Rev 2 (MSD Landscape Guide)

Maryland Stormwater Design Manual Volumes I and II, Revised May 2009

Rules, Regulations, and Engineering Design Requirements for Sanitary Sewer and Stormwater Drainage Facilities, MSD, February 2006 as amended

The following technologies shall be used capture and treat the required extended detention volume. The design procedure and design requirements can be found in this manual.

Permitted Best Management Practice
Infiltration with Controlled Release
Volume Storage with Controlled Release
Permeable Pavements with Controlled Release
Amended Soils

Table 1. Stormwater Technology Table

A checklist with minimum submittal requirements is included in *Appendix 1*.

Sample details are in *Appendix 2*.

3. Applicability

The applicability of the stormwater regulations is described in Section 506.060 and Section 506.310 of the Frontenac Municipal Code which is repeated below.

Site plans should only be submitted to one agency for stormwater review, Frontenac or MSD. The area of land disturbance determines the reviewing agency for stormwater. If land disturbance is less than 1 acre, site plans should be submitted to Frontenac for stormwater review. If land disturbance is 1 acre or greater, site plans should be submitted to MSD for review. While the lot size may be 1 acre or larger, it is the amount of land disturbance that is the determining factor for the appropriate stormwater review agency. In most cases, site plan review will be done by Frontenac.

There has been some confusion attributed to the term “water quality volume”* as it is used in the Code. The term, as used in the Frontenac Municipal Code, refers to the volume of water that shall be held in extended detention. It is preferred that the method chosen to provide the extended detention will also promote infiltration. Bio-retention systems are preferred to underground systems because of their sustainability, and for ease of inspection. *(Note: formatting from following follows specification formatting:*

SECTION 506.060: APPLICABILITY

A. This Article shall be applicable to all land disturbance activity, including, but not limited to, site plan applications, subdivisions applications, building permit and excavation applications, unless specifically exempted herein. These provisions apply to any new development or redevelopment site within the City that meets one (1) or more of the following criteria:

1. Any new development or redevelopment, regardless of size that is identified by the City to be an area where the land use has the potential to generate contaminated runoff;
2. Additional impervious cover that exceeds ten percent (10%) of the lot area or one thousand (1,000) square feet, whichever is less.

B. Exemptions. The following activities are exempt from this Article:

1. Projects that are exclusively for agricultural and silvicultural uses. (Agricultural or silvicultural roads that are used to access other land uses subject to this Article are not exempt. Agricultural structures that are also used for other uses subject to this Article are not exempt.);
2. Maintenance and repair to any stormwater BMP deemed necessary by the City;
3. Any emergency project that is immediately necessary for the protection of life, property, or natural resource;
4. Linear construction projects, such as pipeline or utility line installations that do not result in the installation of any impervious cover, as determined by the City. (Such projects must be designed to minimize the number of stream crossings and width of disturbance, and are subject to the supplemental stormwater regulations of this Chapter and any other applicable municipal, State and Federal regulations); and

*See Section 506.310 of the Frontenac Municipal Code.

5. Any part of a land disturbance that was approved by the City prior to the effective date of this Chapter. (Ord. No. 2010-1621 §1, 4-20-10)

SECTION 506.310: *WATER QUALITY CRITERIA

Structural and non-structural stormwater BMPs shall be used to prevent or minimize water quality impacts from land development. The applicant shall be subject to the requirements of (1), (2) and (3) below if the project's land disturbance is less than one (1) acre; otherwise, the applicant shall follow St. Louis Metropolitan Sewer District (MSD) requirements in Chapter 4 of "Rules and Regulations and Engineering Design Requirements for Sanitary Sewer and Stormwater Drainage Facilities" February 2006, or latest revision.

1. Water quality volume standard. Structural practices shall be designed to capture and treat, at a minimum, the water quality volume (WQv) in cubic feet. The WQv shall be computed as follows:

$WQv = [P \times DI]/12$, where:

P = 1-year 24-hour rainfall depth of 2.5 inches

DI = is the increase in impervious cover (square feet)

Land disturbance that qualifies as redevelopment, and exceeds two thousand (2,000) square feet of increased impervious area, except for swimming pools, and other miscellaneous accessory structures as approved by the Building Commissioner and Zoning Administrator, shall also meet one (1) of the following criteria:

- a. Reduce existing site impervious cover by at least twenty percent (20%);
- b. Provide treatment for at least twenty percent (20%) of the site's pre-development impervious cover through stormwater BMPs designed in accordance with the criteria in the Frontenac Stormwater Regulations and the Stormwater Design Manual;
- c. Contribute to a watershed project that is acceptable to the City; or
- d. Any combination of impervious cover reduction, stormwater treatment, and contribution to a watershed project acceptable to the City.

2. Technology standard. Structural and non-structural practices shall be selected from the Stormwater Technology Table in the Stormwater Manual and sized and designed according to the standards in the manual.

3. Additional criteria for stormwater hotspots. In addition, stormwater discharges from stormwater hotspots may require the use of specific structural, non-structural, and/or pollution prevention practices, including enhanced pre-treatment. Discharges from a stormwater hotspot shall not be infiltrated without enhanced pre-treatment, as approved by the City. (Ord. No. 2010-1621 §1, 4-20-10; Ord. No. 2011-1648 §1, 4-19-11)

4. Design Procedure for Best Management Practices

There are three volumes that shall be calculated in the design process. These calculations shall be on the plans.

- Required Extended Detention Volume (REDv)
- Extended Detention Volume Provided (EDvP) to Best Management Practice
- Capacity of Best Management Practice

Calculations for extended detention shall follow City of Frontenac Criteria as follows:

- A. The Required Extended Detention volume shall be calculated by multiplying 2.5 inches over the increased impervious area. Generally, if the increased impervious area exceeds 2,000 sf, and the project includes work on the primary structure, then include 20% of the existing impervious area in the calculation. This is the minimum amount of Extended Detention volume that may be used to size the BMP.

$$REDv = (\text{Increased Impervious Area} + 20\% * \text{Existing Impervious Area})\text{sf} * (2.5/12)\text{ft}$$

- Pervious pavement designed to hold 2.5 inches of rain in the void space of its clean aggregate base with controlled release is considered to be pervious. If it is counted as pervious, there shall be an accompanying Maintenance Agreement.
 - Water surface of the pool (existing or proposed) is not counted towards impervious area.
- B. Then check the contributing drainage area to the BMP. If feasible, the contributing drainage area should be on the same property as the BMP. The drainage area shall provide +/- 10% of the Required Extended Detention volume to the BMP. If it exceeds 10% of the Required Extended Detention volume, the BMP shall be sized to handle that volume or the excess drainage shall be diverted. The following formula and values shall be used to calculate the Extended Detention volume Provided by the contributing drainage area:

$EDvP = [(P)(RV)(A)]/12$	
Where:	
EDvP	= Extended Detention volume Provided (in cubic feet)
P	= 2.5 inches of rainfall
RV	= $0.05 + 0.009(I)$ where I is percent impervious cover
A	= contributing area in square feet

Table 2. Extended Detention Volume Provided Formula

- At the designer’s option, if the drainage area to the BMP is more than 25% impervious, the Extended Detention volume from the contributing drainage area may be calculated as follows: (the contributing impervious area * 2.5 / 12).

C. Generally, there are two basic types of best management practices that are used. The first involves infiltration with controlled release such as in bio-retention. The second involves volume storage and controlled release. They are sized differently. If you want to treat an infiltration type BMP as a volume storage BMP, see the procedure in “Other Methods”. If you are working on a site with an existing City approved infiltration practice and would like to modify the existing basin without increasing the filter bed, see the section entitled “Bio-retention retrofit” under “Other Methods”.

The bio-retention system shall be sized according to the following equation with the coefficients provided in the table below:

$$A_f = \frac{(\text{REDv or EDvP}) * d_f}{[k * (d_f + h_f) * t_f]}$$

Where:	
A_f	= filter bed area (sf)
REDv or EDvP	= Required Extended Detention volume or, if additional capacity is desired, Extended Detention volume Provided to the bio-retention system by its drainage area (in cubic feet)
d_f	= filter soil depth minimum of 1.5 feet (includes sand layer) (ft)
K^a	= 0.5, coefficient of permeability (ft/day)
h_f^b	= average height of water above filter bed (half the ponding depth, ft)
t_f	= 2, design filter bed drain time (days)

Table 3. Bio-Retention Sizing Formula and Required Coefficients

- The City of Frontenac requires the coefficient of permeability to be set at 0.5 ft/day regardless of tests run on the planting soil. This is to provide for some pore clogging in the future and to match the release rate controlled by the outfall orifice (see section on Best Management Practice Discharge).
- Total ponding depth shall be measured from the top of the planting soil, not the top of mulch or pea-gravel.

The storage and controlled release best management practice shall be sized based on the storage volume it provides. If using clean rock, 40% void space shall be used. For bio-retention soil, 30% void space shall be used.

4.1 Example

Step 1

The proposed project will replace an existing home. The existing impervious area is 5,051 sf. The proposed impervious area is 9,551 sf. The increased impervious area is 4,500 sf. Since the increased impervious area is greater than 2,000 sf and includes the primary structure, extended detention must also account for 20% of the existing impervious area. Therefore the Required Extended Detention Volume shall be calculated as follows:

$$RED_v = (4,500 + 0.2 * 5,051) \text{sf} * 2.5 \text{in} / 12 \text{in/ft} = 1148 \text{ cf}$$

Step 2

The next step is to calculate the EDvP to check that the drainage area to the BMP is providing the appropriate amount of flow. The whole house (5,000 sf) and most of the pervious back yard (16,000sf) drains to the BMP. Therefore the total drainage area is 21,000sf and the percent impervious is 23.8. Because the percent impervious is less than 25%, the EDvP shall be calculated using R_v.

$$R_v = 0.05 + 0.009 * 23.8 = 0.264$$

$$EDvP = (2.5 \text{ in} * 0.264 * 21,000 \text{ sf}) / (12 \text{ in/ft}) = 1155 \text{ cf}$$

EDvP shall be +/- 10% of RED_v or 1033 cf < EDvP < 1263 cf

1155 cf falls within the appropriate range so no adjustments are needed. If EDvP was too small, the drainage area to the BMP would need to be increased. If EDvP was too large, excess volume would need to be diverted or the size of the BMP would need to be increased to handle the larger volume.

Step 3

The last step in this process is to size the BMP based on the RED_v or, if the EDvP is greater than 110% of the RED_v, to be within 10% of the EDvP. This example will size a bio-retention solution and an underground rock storage solution.

Bio-retention

Assuming a filter bed depth of 3 feet (includes sand layer) and ponding depth of 1 foot, calculate the surface area of the bio-retention planting soil:

$$A_f = (1148 \text{ cf} * 3 \text{ ft}) / [0.5 \text{ ft/day} * (3.0 \text{ ft} + 0.5 \text{ feet}) * 2 \text{ days}] = 984 \text{ sf}$$

The surface area for the bio-retention shall be 984 sf or greater.

Underground rock storage

Taking the porosity of the rock to be 40%, the required volume of the underground storage would be

$$\text{Volume of underground storage} = 1148 \text{ cf} / 0.4 = 2870 \text{ cf}$$

Assuming an available area of 20 feet by 50 feet, the thickness of the underground rock storage could be calculated as follows:

$$\text{Thickness of storage} = 2870 \text{ cf} / (20 \text{ ft} * 50 \text{ ft}) = 2.9 \text{ ft}$$

4.2 Other Methods

4.2.1 Sizing bio-retention based on its storage volume capacity

You can use this procedure to determine the volume capacity of the bio-retention. Using this procedure may limit the available capacity of a retrofit.

There is the above ground holding volume and the pore space volume of the soil which takes time to fill.

- A. Back calculate the rainfall depth to fill the above ground holding volume.
- B. Determine the time it takes to fill the above ground volume using the most intense part of an SCS Type II 24-hour, 2.5-inch rain, assuming 15 minutes increments of time.
- C. Assuming an infiltration rate of 0.5 ft / day, calculate the depth of infiltration based on that infiltration rate and the time to fill the above ground volume.
- D. Calculate the infiltrated volume base on 30% voids.
- E. Double the infiltrated volume to account for new volume available above ground.
- F. Add volume from step 5 to original above ground volume to obtain the volume capacity of the bio-retention.

4.2.2 Amended Soils

Amended soils will only be allowed in heavily wooded or vegetated areas where regular traffic is less likely and therefore the opportunity to compact the soil is lessened. A BMP reserve around the area and associated Maintenance Agreement will be required. The ratio of amended soils to impervious area would need to be 2.44 based on Table 2-1 in TR-55 for an Impervious Curve Number of 98 (larger rains produce proportionally more runoff).

4.2.3 Bio-Retention Retrofit

If the existing condition includes a City of Frontenac approved bio-retention facility, it may be possible to alter the grading around the facility to accommodate new impervious area. Up to an additional 30% of the water volume used to size the bio-retention can be stored around

and drain to the bio-retention without creating additional filter bed. The additional volume shall be compared to the volume above the existing bio-retention surface assuming 3H:1V side slopes up to the maximum ponding depth. When calculating the existing volume, a minimum of 5 survey shots shall be averaged to determine the bio-retention surface elevation and the low point on the berm shall also be surveyed.

5. Design Requirements

5.1 Bio-Retention Design

The MSD Landscape Guide shall be followed when designing bio-retention as well as the guidelines below. If there is a conflict, the guidelines below shall govern.

Design Considerations

- A. Bio-retention cleanouts shall have removable caps and, if inside ponding area, have a top elevation at or above the maximum ponding depth.
- B. There are several different planting soil layer thicknesses that could be used depending on the circumstances.
 - In general bio-retention basins should have 2.5 feet of planting soil with 6 inches of washed sand between the planting soil and the clean 3/8" diameter gravel.
 - Where elevations restrict the soil depth in the bio-retention basin, the planting soil thickness may be reduced to a minimum of one foot.
 - It is preferred for the underdrain to have a continuous downward slope, however, bio-retention with internal water storage, such as in Detail 5 of the MSD Landscape Guide for Stormwater Best Management Practice Design, may be used. In this case the planting soil or bio-retention soil mix shall have a minimum thickness of 2 feet and the invert of the discharge pipe shall not exceed the elevation of the bottom of the planting soil.
- C. Cross-section: The minimum (top to bottom) cross-section requirements for bio-retention systems are:
 - 2-inches of mulch (single or double shredded hardwood mulch) or pea-gravel
 - 1-foot of bio-retention soil (2.5 feet is preferred)
 - 6-inch layer of washed concrete sand (ASTM C-33 Fine Aggregate)
 - 4-inch layer of uncrushed, natural pea gravel, 3/8-inch diameter (ASTM C-33 No. 8)
 - 8-inch layer of 3/4-inch diameter gravel (ASTM-33 No. 6 or 67) as the gravel base
- D. Underdrains
 - Minimum of 3 inches of clean rock over underdrain
 - 4 inches of clean rock below underdrain flowline
 - 4 or 6-inch perforated PVC pipe shall be used for the underdrain
 - 4 or 6-inch solid PVC pipe shall connect to perforated pipe one foot before underdrain leaves the bio-retention
 - Underdrains shall have cleanouts at their upstream end
 - All open ends shall be capped

E. Filter fabric

There shall not be a horizontal layer of filter fabric at any level above the underdrain. If subsidence is a concern, at a minimum, provide filter fabric on the sides from the bottom of the 3/4" gravel to the bottom of the sand layer. Filter fabric may be placed underneath the 3/4" gravel at the designer's option. If subsidence is not a concern, filter fabric may be placed at a 4-foot width, centered under the underdrain and brought up vertically to the base of the sand layer.

F. Provide 6 inches of freeboard from top of Bio-retention berm to low sill of house.

G. Bio-retention should be a minimum of 10 feet from foundation walls. If this criterion cannot be met, the underground portion of the bio-retention facility shall be lined with plastic (minimum 6 mil) sheeting within 10 feet of a foundation wall.

Planting Plan

A. Provide planting plan and specify bio-retention plantings and spacings in accordance with the MSD Landscape Guide plant lists.

Notes and Plan Requirements

A. The location of the BMP Reserve shall be shown on the plan.

B. Add note that limestone shall not be used in bio-retention.

C. Provide side dimensions of Bio-retentions on the site plan for easy field verification.

D. Add note that bio-retention backfill shall not be compacted or driven on by rubber wheeled heavy equipment.

E. Material specifications for bio-retention basins shall be shown on the plans per MSD Landscape Guide.

F. The following elevations shall be identified:

- Top of Berm
- Surface of bio-retention
- Underdrain invert
- If in proximity of a structure, low sill of structure

5.2 Volume Storage and Controlled Release BMPs

BMPs that are based on volume storage may be above ground, below ground or combined above and below ground.

If the storage is above ground, some kind of filter will be needed before the water reaches the outfall orifice. A minimal design would place a 6-foot long perforated pipe in a 1-foot wide trench. The perforated pipe would have 4-inches of 3/4-inch clean rock under it with 6-inches

of 3/4-inch clean rock over it. There would be a 6-inch layer of 3/8-inch pea gravel above the 3/4-inch clean rock. The top of this layer would be at the low point of the above ground basin.

If any part of the storage is below ground, some pre-treatment is required. Minimal examples include:

- Gutter Protection Systems such as Leaf Guard Gutter by Englert (<http://www.leafguard.com/>) or Gutter Helmet (<http://www.gutterhelmet.com/>) shall be specified for all gutters tied to the BMP.
- Filter structure (such as Nyloplast “Snout” filter structure or EnviroHood both with minimum 6-inch basin sump, or NDS Catch Basin Filter with minimum 6-inch basin sump) before stormwater enters BMP. Structure details shall be shown on the plans.

Typically, underground storage will have a feeder pipe, an underdrain, and may have an overflow pipe. None of these shall be directly connected inside the BMP. The underdrain and overflow pipe may be connected downstream of the outfall orifice. Cleanouts shall be provided at the beginning and end of the perforated feeder pipes as well as on the ends of the underdrain and overflow pipes.

5.3 Underdrain Requirement

All BMPs are required to have underdrains unless percolation and infiltration tests, described in the Maryland Manual Appendix D.1, have been completed and show an adequate infiltration rate.

Perforated underdrains shall be laid on four inches of clean rock. The clean rock shall extend to the BMP limits. Perforations shall be 3/8” diameter at 5 and 7 O’clock and on 6-inch centers.

5.4 Best Management Practice Discharge

In order to ensure captured water is released at the desired rate, an outfall orifice shall be used to restrict the outflow for all best management practices. Generally the orifice takes two forms. For those outfalls that daylight or connect to a private system, a screw on plug with four holes is used. If the system ties into an MSD storm system or has a deep connection a backwater valve installed in reverse with four holes drilled in a surface removable flap is used. The four holes shall be drilled in a diamond pattern.

The following criteria shall be used to specify the outfall orifice hole size:

For WQv less than value below (cf)	4 holes of this diameter required
350	1/8"
800	3/16"
1500	1/4"
3300	3/8"
6000	1/2"
9075	5/8"

Table 4. Outfall Orifice Hole Sizing Requirements

Design Considerations

- A. Where possible, best management discharges shall be tied into public storm sewers or structures.
- B. The outfall orifice shall be accessible for cleaning. If a catch basin is used, and the outfall orifice is deeper than 24 inches, the catch basin shall be 30-inch diameter or greater.
- C. Discharge lines from best management practices shall have minimum slopes of 0.5%.
- D. Stormwater discharge is required to be at least 10 feet from the property line and cannot create a nuisance to adjoining properties. This includes the Right-of-Way line. If the developer wishes to daylight the outfall on an adjacent property, the City must approve the outfall location and the developer must provide a recorded easement that allows him to construct and maintain the stormwater system that crosses the property line.
- E. Provide flow line elevation of discharge line outfall. Show contours in vicinity of outfall.
- F. In some cases it may be appropriate to drain the discharge into a one foot deep or deeper trench filled with 2 to 4-inch clean rock that has an area of 8 square feet or more (preferably with 8 feet perpendicular to the discharge pipe to act as a level spreader.)

5.5 Drainage Areas

Provide existing and proposed conditions drainage area maps to show off-site to on-site drainage. Calculate 15-year 20 minute flows for these drainage areas. The proposed drainage area shall assume the 15-year 20 minute peak flow bypasses the BMP. On proposed drainage area map, show the drainage area to the BMP.

5.6 Drainage Structures

- Provide top, sill and flowline elevations for area inlet.
- Provide details for drainage structures.
- Show orifice or weir calculations as appropriate for inlets to show adequate capacity.

5.7 Siltation Control

- Show siltation control at downhill limits of grading and at appropriate limits up the slope.
- Show siltation control uphill of BMPs.
- Provide siltation control details.
- Rock check dams or other appropriate devices are to be used for siltation control in swales and other areas of concentrated flow.
- Silt Fence should not be used across concentrated flow paths or have more than ¼ acre draining to each 100 linear feet of fence.
- Silt Fence shall be placed in parallel rows on slopes with row spacing as follows:
 - 30 foot maximum for 3:1 slopes
 - 50 foot maximum for slopes between 3:1 and 10:1
 - 100 foot maximum for slopes under 10%

5.8 Pop-ups

If a pop-up is to be used, install 10 feet of perforated pipe prior to the pop-up emitter. The perforated pipe shall be surrounded by a minimum of 6 inches of $\frac{3}{4}$ inch clean rock on all sides. The clean rock shall be wrapped in filter fabric.

5.9 Materials

- Use of limestone, or other calcareous stone, is not allowed in best management practices.
- Rock used in best management practices shall be washed, clean and hard.
- Pipe types shall be limited to SDR-35, Schedule 40 PVC, dual walled N-12 WT IB, and reinforced concrete pipe.
- Perforated pipe shall have $\frac{3}{8}$ " diameter perforations on 6-inch centers at 5 and 7 O'clock.
- Filter Fabric shall be a nonwoven geotextile adhering to MSD Type 4 standards.

6. Maintenance Agreements

All BMPs are required to have recorded Maintenance Agreements. Typically the agreement will have a cover sheet, script, Exhibit “A” and Exhibit “B”. Sample agreements are in *Appendix 3*. Maintenance Agreements shall be submitted for review and approval before recording.

Maintenance Agreements shall require inspection and maintenance procedures for the whole system, from the gutters to the outfall.

For bio-retention facilities, the Maintenance Agreement shall require that plant density be maintained as described in the MSD Landscape Guide.

All maintenance agreements shall have a statement to the effect: “The best management practice is designed to drain in 48 hours after the rain event has stopped. If this period is routinely exceeded after all prescribed maintenance is performed, the entire facility may need to be reinstalled.”

APPENDICES

APPENDIX 1
SITE PLAN CHECK LIST

Site Plan Checklist

(The items listed below are minimum submittal requirements, additional information may be required.)

Digital or paper plan sets may be submitted for review. Two (2) paper copies of the site plan, sealed by a Missouri registered civil engineer and drawn to scale will be required after approval is given. The submitted plans should indicate the following:

- ❑ Location map.
- ❑ Scale of plans (minimum 1 inch = 40 feet).
- ❑ North arrow.
- ❑ Location of property lines and easements, setbacks, utilities, sewer, water, gas, electric.
- ❑ Location and dimensions of proposed construction and distances to the property lines.
- ❑ Dimension of existing structure with foundation elevation (if demo).
- ❑ Location of streets and street right of ways.
- ❑ Existing and proposed contours at one-foot intervals based on USGS Datum.
- ❑ Existing and proposed finish floor elevations (Proposed not to exceed 12" inches higher than existing).
- ❑ Drawings shall include the following elevations and info: basement floor, top of first floor, top of foundation, finish grade elevations at corners, down spout locations.
- ❑ Street elevation in front of home.
- ❑ Erosion control (include detail for silt fence or other measures).
- ❑ Total square footage of lot with acreage conversion.
- ❑ Show green space calculations. R-1 60%, R-2 55% front yard.
- ❑ Maximum finish grade slope not to exceed 3:1.

Stormwater:

- ❑ Show all existing and proposed impervious areas, tabulate square footage of each.
- ❑ For impervious areas increased over 1,000 sf, calculate excess stormwater based on 2.5" of rain over total increase in impervious area. If increase is over 2,000 sf and related to the main structure, generally add 20% of the existing impervious area to the increase in impervious area.
- ❑ Detailed plan for excess storm water remediation (for example: Bio-retention).
- ❑ Drainage area map with calculations for all on-site water runoff and incoming water runoff.
- ❑ Management plan for all storm water runoff, on-site combined with off-site influence.
- ❑ Indicate drainage with directional arrows.
- ❑ No diversion of storm water will be allowed without adequate plan to address it.
- ❑ Note any blocked storm water structures to be cleared.
- ❑ Include detail for swales.
- ❑ For flows greater than 0.1 cfs, provide calculations to show minimum freeboard to grade against the structure on swales to be 6-inches at critical points.
- ❑ Longitudinal slope of grass swales: minimum 2% and maximum 6%.
- ❑ Maximum CFS (cubic feet per second) through swales is 4 CFS.

If the property is located in a subdivision you will need to obtain trustee approval prior to submitting for a permit. The trustees granting approval will need to print their name, sign, and date the plans. A minimum of two (2) trustees must sign.

APPENDIX 2
EXAMPLE DETAILS

Details

Downspout Connector

Bio-Retention Cross-Section

Underground Rock Storage

Outfall Orifice

Backwater Valve

Rock Ditch Check

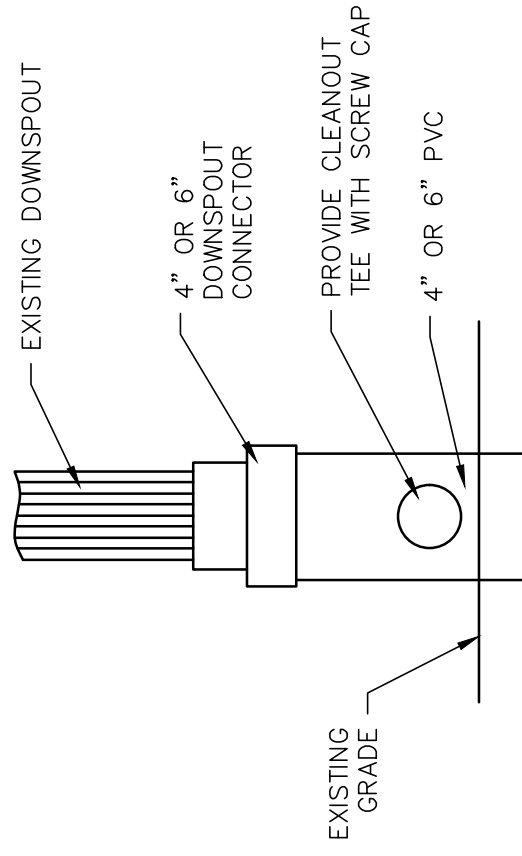
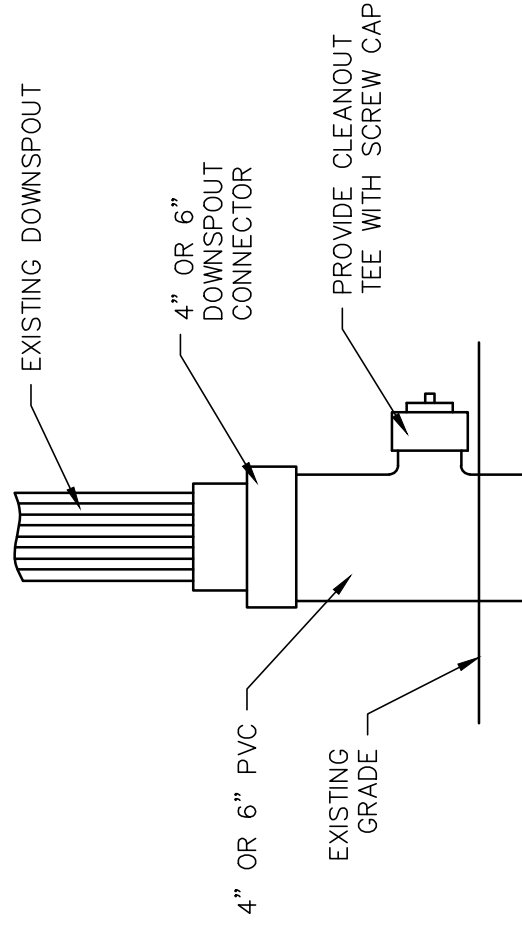

DOWNSPOUT CONNECTOR

NOT TO SCALE

DOWNSPOUT CONNECTOR TO
MATCH COLOR OF DOWNSPOUT

PLACE TEMPORARY FILTER FABRIC OVER TOP AND DOWN FOUR INCHES ON THE SIDES TO PROTECT BIO-RETENTION UNTIL GROUND COVER IS FULLY ESTABLISHED. THEN REMOVE TOP PORTION FOR PLANTING.

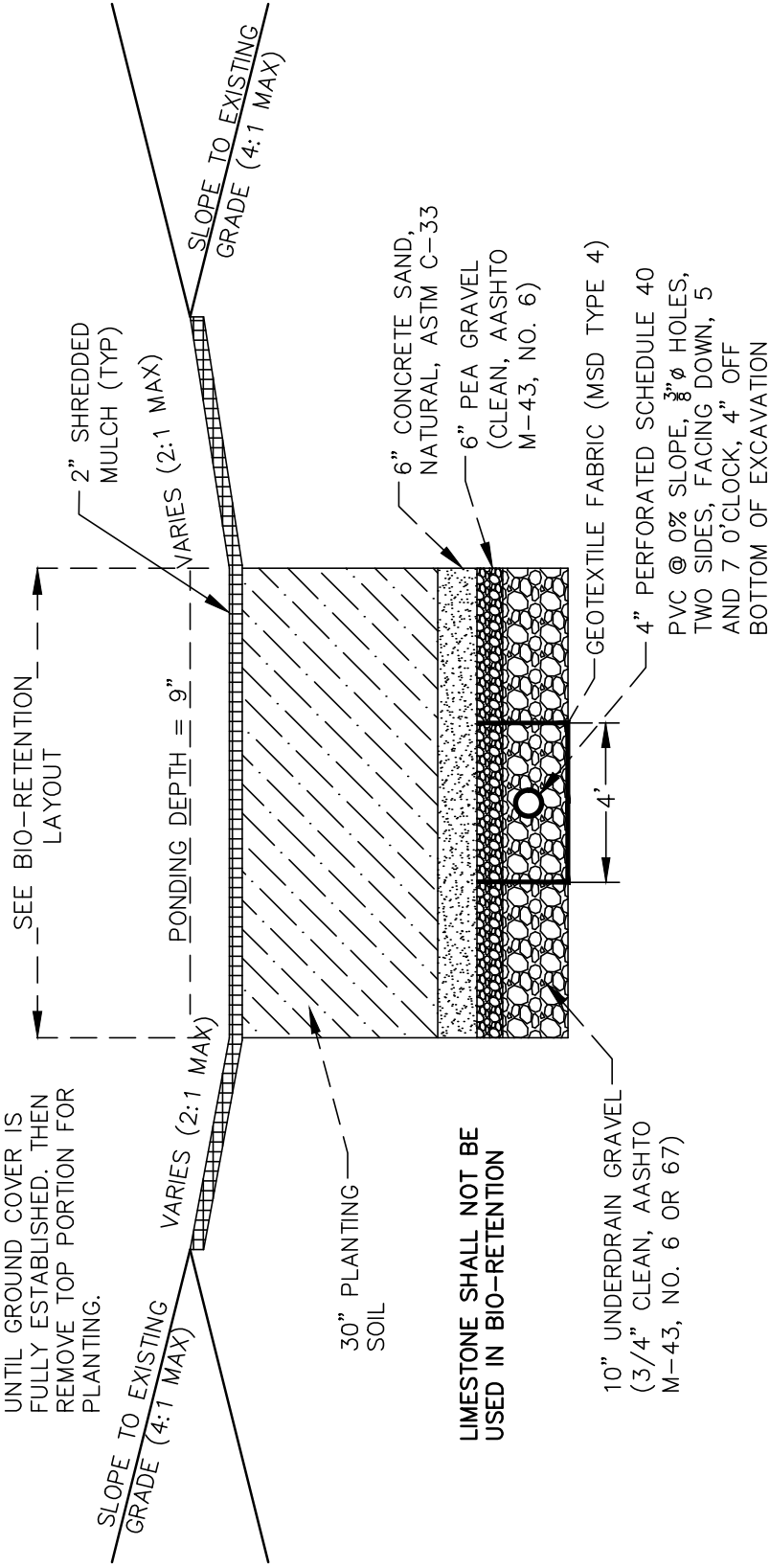

BIORETENTION TYPICAL SECTION

SCALE: N.T.S.

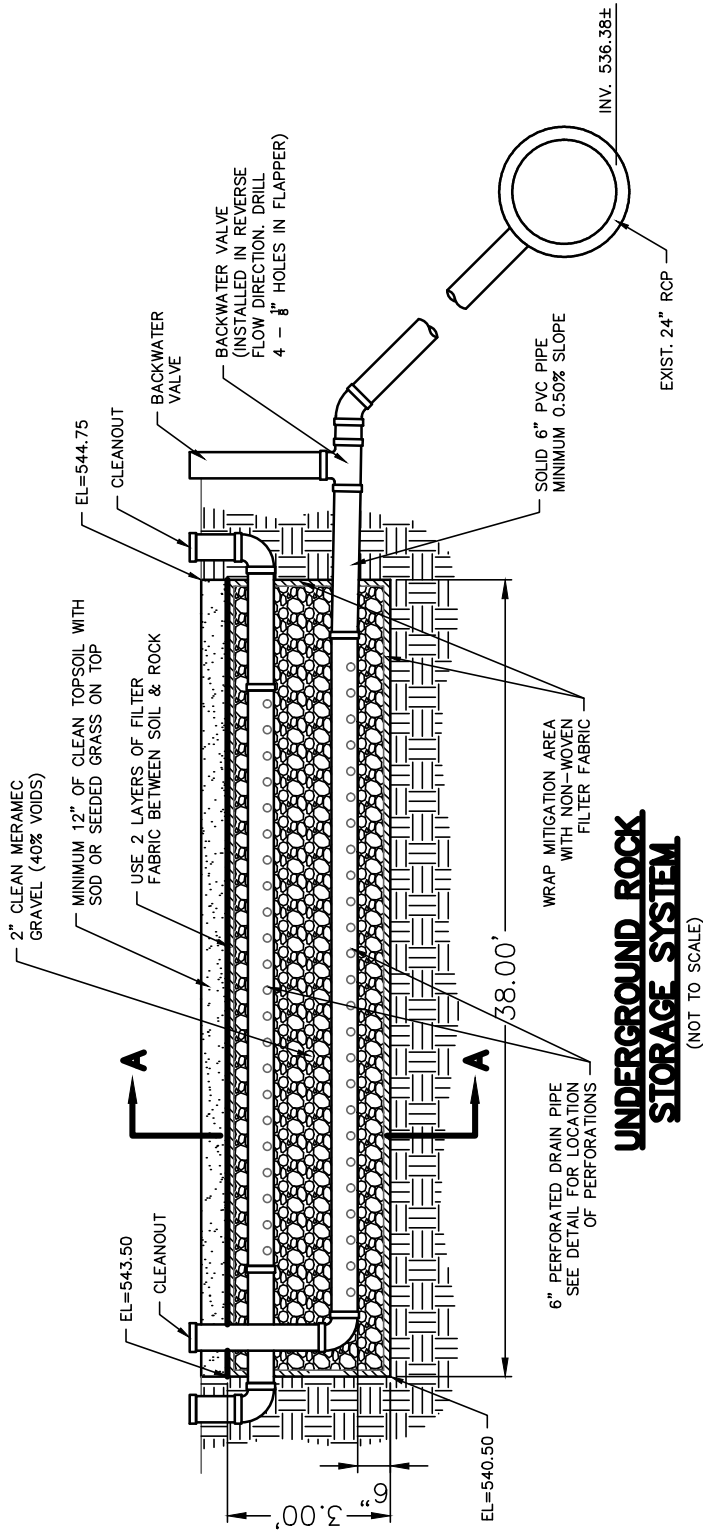

UNDERGROUND ROCK STORAGE SYSTEM
(NOT TO SCALE)

NOTE: LIMESTONE SHALL NOT BE USED IN UNDERGROUND ROCK STORAGE SYSTEM

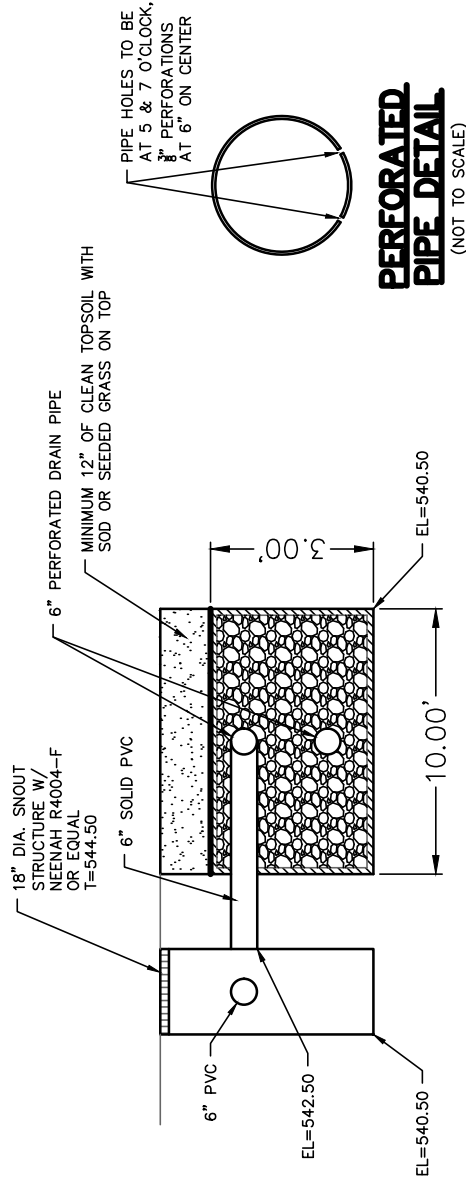

SECTION A-A
(NOT TO SCALE)

PVC

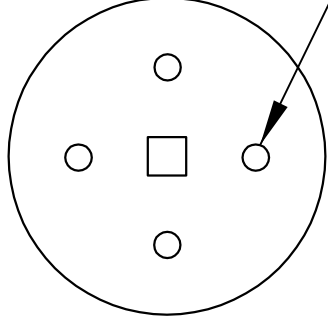
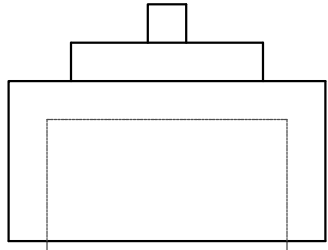

DRILL 4 HOLES
3/8" IN DIAMETER
SCREW ON PVC ORIFICE
AFTER TWO RAINFALLS ON
NEW RAIN GARDEN

OUTFALL ORIFICE



BACKWATER VALVES

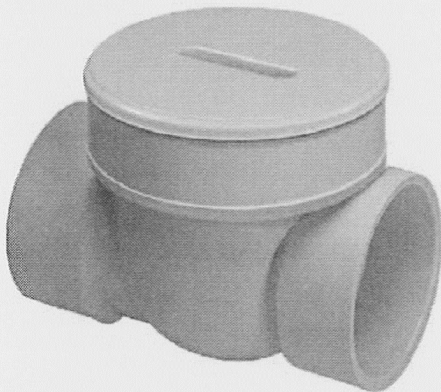

Standard Valve

- All PVC Construction with EPDM Flapper Seal
- Threaded Top Plug for Convenient Service
- Simple Snap-In Internal Flapper Assembly for Easy Replacement
- Optional Factory Assembled Service-Access Extension Kits - External Housing with Internal Extension for Convenient Removal, Inspection or Replacement
- Optional Extension Components Kits for Assembly with User-Supplied Pipe
- Available in Sizes 2", 3", 4" and 6" with Socket Ends
- Direct Connection to ASTM D 2665 PVC DWV or other IPS size pipe. Spears® IPS x Sewer Adapters Available for Connection to ASTM 3034 Sewer
- Conforms to ASME/ANSI A112.14.1 for Backwater Valves
- Pressure Rated to 43 psi (100 feet of head) @ 73°F

Sample Engineering Specification

All thermoplastic valves shall be Backwater type constructed from PVC Type I, ASTM D 1784 Cell Classification 12454. All Valve Seats shall be EPDM. All valves shall have external Arrow Flow Indicator. All valves shall be pressure rated to 43 psi (100 feet of Head) for water @ 73°F as manufactured by Spears® Manufacturing Company.

Quick-View Backwater Valve Selection Chart Standard Valve

Valve Size	Seat Material	PVC Material	Pressure Rating
		Socket	
2	EPDM	S275P	43 psi (100 feet of Head)
3	EPDM	S375P	
4	EPDM	S475P	
6	EPDM	S675P	

Features - PVC White

Backwater Valves are designed to prevent backflow in numerous applications where easy service access for maintenance and cleaning is needed. Excellent for use in sanitary or storm sewer drainage systems to prevent waste back up due to inadequate drainage, for balancing multi-level ponds, aquaculture features or storage tank systems, and many other applications. Spears® Backwater Valve has been engineered for improved function and easier service, especially in buried service with use of optional Service-Access Extension Kit.

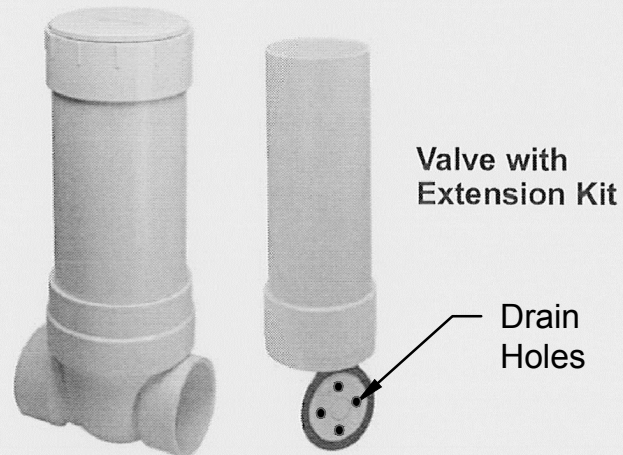

Valve with Extension Kit

Drain Holes

PVC Service-Access Extension Kit Options:

Available as a complete unit, with or without valve, factory assembled to internal flap assembly, extension pipe, and external extension housing with top access adapter in convenient increments of 12", 16", 20", 24", 36", and 48" (measured from top of valve to top of extension). All extension kits can be cut shorter in the field for custom fits. Also available as Extension Components Kits, with or without valve for assembly with user-supplied Class 125 or Schedule 40 pipe. Kits without valve require use of existing valve top Access Plug, all kits require solvent cement assembly to valve. Contact Spears® for pricing on custom cut lengths.

Quick View Extension Components Kit Options

Extension Adapters and Flap Assembly with or without valve. Must be assembled with user-supplied Class 125 or Schedule 40 Pipe.

Valve Size	Socket Valve With Extension Component Kit	Extension Component Kit Only	Pressure Rating
2	S275P-AK	S275P-ECK	43 psi (100 feet of head)
3	S375P-AK	S375P-ECK	
4	S475P-AK	S475P-ECK	
6	S675P-AK	S675P-ECK	

BACKWATER VALVES



Quick View Backwater Valves with Extension Kit to Premade Lengths

Socket Valve with complete Extension Assembly in precut lengths.

Valve x Extension Size ¹	Socket Valve With Extension	Valve x Extension Size ¹	Socket Valve With Extension	Pressure Rating
2 x 12HT	S275P-120	4 x 12HT	S475P-120	43 psi (100 feet of head)
2 x 16HT	S273P-160	4 x 16HT	S473P-160	
2 x 20HT	S275P-200	4 x 20HT	S475P-200	
2 x 24HT	S275P-240	4 x 24HT	S475P-240	
2 x 36HT	S275P-360	4 x 36HT	S475P-360	
2 x 48HT	S275P-480	4 x 48HT	S475P-480	
3 x 12HT	S375P-120	6 x 12HT	S675P-120	
3 x 16HT	S373P-160	6 x 16HT	S673P-160	
3 x 20HT	S375P-200	6 x 20HT	S675P-200	
3 x 24HT	S375P-240	6 x 24HT	S675P-240	
3 x 36HT	S375P-360	6 x 36HT	S675P-360	
3 x 48HT	S375P-480	6 x 48HT	S675P-480	

¹ - Size designates nominal valve size x extension height (HT-top of valve to top of extension, inches).

Quick View Service Access Extension Kit Only In Premade Lengths (valve not included)

Extension Assembly in precut lengths. Use exiting valve top Access Plug.

Size ¹	Premade Extension	Size ¹	Premade Extension	Pressure Rating
2 x 12HT	SAEK-020-120	4 x 12HT	SAEK-040-120	43 psi (100 feet of head)
2 x 16HT	SAEK-020-160	4 x 16HT	SAEK-040-160	
2 x 20HT	SAEK-020-200	4 x 20HT	SAEK-040-200	
2 x 24HT	SAEK-020-240	4 x 24HT	SAEK-040-240	
2 x 36HT	SAEK-020-360	4 x 36HT	SAEK-040-360	
2 x 48HT	SAEK-020-480	4 x 48HT	SAEK-040-480	
3 x 12HT	SAEK-030-120	6 x 12HT	SAEK-060-120	
3 x 16HT	SAEK-030-160	6 x 16HT	SAEK-060-160	
3 x 20HT	SAEK-030-200	6 x 20HT	SAEK-060-200	
3 x 24HT	SAEK-030-240	6 x 24HT	SAEK-060-240	
3 x 36HT	SAEK-030-360	6 x 36HT	SAEK-060-360	
3 x 48HT	SAEK-030-480	6 x 48HT	SAEK-060-480	

¹ - Size designates nominal valve size x extension height (HT-top of valve to top of extension, inches). All extension kits can be cut shorter in the field for custom fits.

STANDARD VALVE

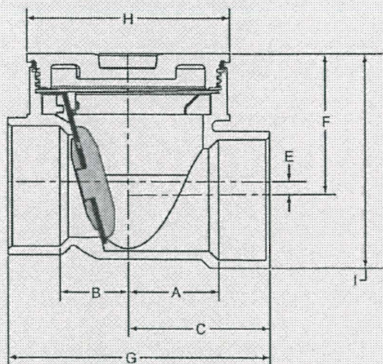

Standard Valve Dimensions (Inches)

Size	A	B	C	E	F	G	H	I
2	1-13/16	1-3/4	2-5/8	5/16	3-1/4	5-9/32	4-3/16	4-9/16
3	2-5/8	2	4-3/16	13/32	4-1/8	7-3/4	6	6-1/8
4	3-5/8	3-3/4	5-7/16	23/32	5-7/16	10-15/16	8-1/4	7-15/16
6	4-3/4	4-5/8	7-3/4	13/16	7-3/16	15-3/8	11-1/4	10-13/16

VALVE WITH EXTENSION KIT

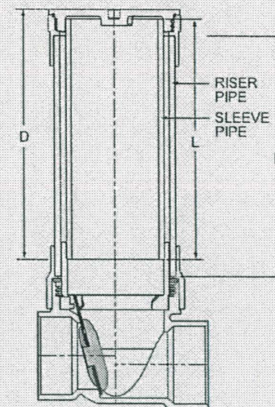

Valve with Extension Kit Dimensions (Inches)

HEIGHT-D	Valve Size			
	2	3	4	6
	L	L	L	L
12	10-3/4	10-7/8	10-1/4	10-1/4
16	14-3/4	14-7/8	14-1/4	14-1/4
20	18-3/4	18-7/8	18-1/4	18-1/4
24	22-3/4	22-7/8	22-1/4	22-1/4
36	34-3/4	34-7/8	34-1/4	34-1/4
48	46-3/4	46-7/8	46-1/4	46-1/4

D = Top of plug Standard Valve to top of plug with Extension

Note: Riser Pipe & Sleeve Pipe are the same length.

ALL TYPES	
DITCH & SLOPE %	DITCH CHECK SPACING (FT.)
0.5	200
1.0	100
1.5	67
2.0	50
2.5	40
3.0	33
3.5	30
4.0	25
4.5	22
5.0	20
5.5	↓
6.0	
6.5	
7.0	
7.5	
8.0	
8.5	
9.0	
9.5	
10.0	

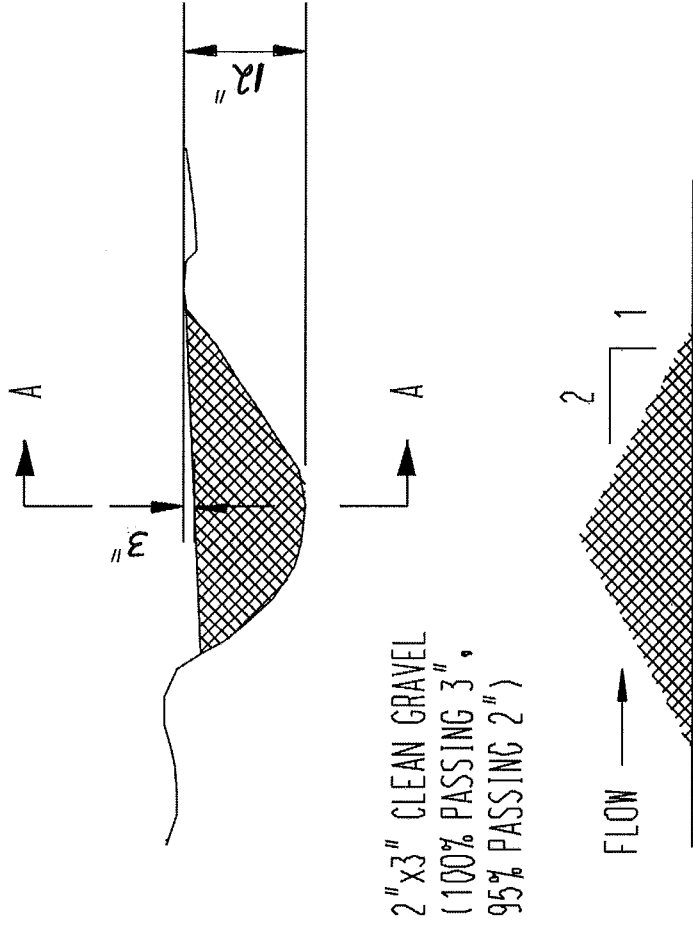

SECTION A

NOTE: THE DITCH CHECK SHALL BE REMOVED WHEN THE GRASS HAS MATURED SUFFICIENTLY TO PROTECT THE DITCH, SWALE, OR THE CONCRETE DITCH LINER HAS BEEN CONSTRUCTED. THE AREA BENEATH THE ROCK DITCH CHECK SHALL BE SEEDED & MULCHED OR CONSTRUCTED IN CONCRETE IMMEDIATELY AFTER THEY ARE REMOVED.

TEMPORARY ROCK DITCH CHECK

APPENDIX 3
EXAMPLE MAINTENANCE AGREEMENTS

Maintenance Agreements

Maintenance Agreements are required for all best management practices. These agreements shall be specific to the property and practice. Maintenance Agreements shall be submitted for review and approval before recording.

This appendix includes sample Maintenance Agreements for the following circumstances:

- Property owned by person with bio-retention
- Property owned by trust with underground rock storage
- Property owned by corporation with underground Storm Tank storage relocated after recording
- Shared BMP between two properties with aboveground storage

File No.: TPA 14 Misc

Title of Document: Maintenance Agreement

Date of Document: October 1, 2014

Grantor(s): John Smith

Grantor's Mailing Address: 1 1250 Adams Drive, St. Louis, MO 63131

Grantee(s): City of Frontenac

Legal Description or Location of Legal Description in the Document: ex A & B

Reference Book and Page:

MAINTENANCE AGREEMENT

KNOW ALL MEN BY THESE PRESENTS, that, John Smith
owners of 1250 Adams Drive for and in consideration of the approval of site plans and of
the issuance of a building permit by the City of Frontenac for new construction in Frontenac
Missouri, at 1250 Adams Drive, and other good and valuable considerations,
do hereby agree and promise, as follows:

1. The stormwater management facilities including Best Management Practices (BMP), basins, berms, embankments, french drains, drainage facilities (drains, yard drains, or inlets and connecting pipes) and appurtenances are to be perpetually located within the dimensioned and reserved area, as shown hachured on the exhibit "A" as attached hereto and made a part hereof.
2. To maintain and operate the stormwater management facilities in conformity with the approved stormwater management design, maintenance and operation plan (attached as Exhibit "B").
3. To maintain all pipes and drains in good working order and maintain all walls, dikes, vegetation, filter media, and any other requisite appurtenances and improvements for the retention and management of stormwater in good repair, in accordance with the design and plans submitted to and approved by the City of Frontenac.
4. That in the event John Smith (his) or (their) successor in title to said property shall fail to maintain the stormwater management facilities including BMPs, basins, berms, embankments, french drains, drainage facilities, appurtenances and sewer lines in accordance with this agreement the City of Frontenac shall be permitted to enter onto the property and make the repairs and corrections and perform such maintenance as it deems necessary and bill the owners of said property for the services performed. It is further agreed that in the event said bill or charge for the services performed shall not be paid within a period of thirty (30) days said sum shall become a lien on the real property and shall accrue interest at a rate of eight percent (8%) until paid in full.
5. This agreement is irrevocable and shall continue forever or until the City of Frontenac no longer requires this Maintenance Agreement.

John Smith

IN WITNESS WHEREFORE, the said _____
Owners of said property, have executed these presents this 1st day of
October, 20 14.

John Smith

John Smith

STATE OF MISSOURI)

) SS.

COUNTY OF ST. LOUIS)

On this 1st day of October, 20 14 before
me personally appeared _____ John Smith _____
to me known to be the person(s) described in and who executed the foregoing instrument, and
acknowledged that John Smith _____ executed the same as
his _____ free act and deed.

IN TESTIMONY WHEREOF, I have hereunto set my hand and affixed my notarial seal, the
day and year first above written.

My Commission expires 8/11/15

Act performed in the County of St. Louis which adjoins the City of St. Louis.

Notary Public

LOT 4

EXA

LOT 5

WATER LANE
(P.B. 47 PG. 78)

N04°20'18"W 213.81'
(N04°16'47"W 213.79' RECORD)

(N04°16'47"W 213.79' RECORD)
S04°20'18"E 213.81'

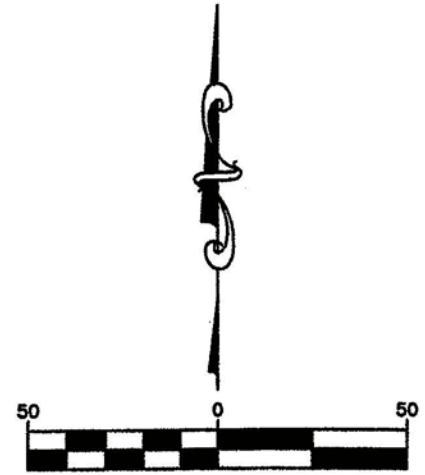

(IN FEET)
1 inch = 50 ft.

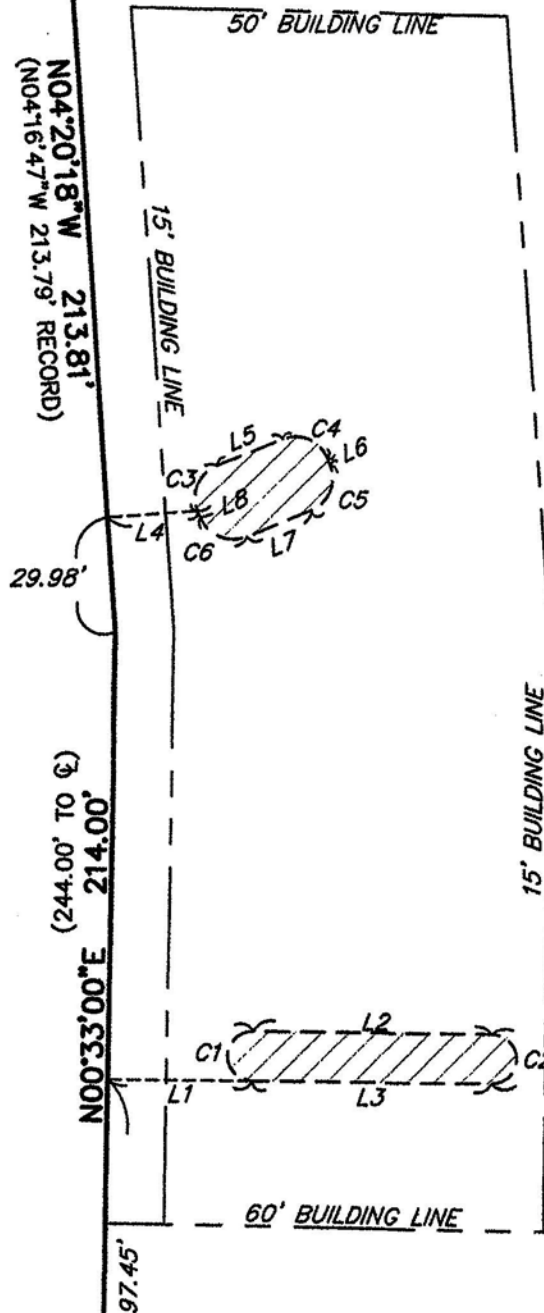

N/F

N/F

LINE INFORMATION

- L1=S89°27'00"E 37.00'
- L2=S89°27'00"E 62.17'
- L3=N89°27'00"W 62.17'
- L4=N85°39'42"E 23.21'
- L5=N67°24'41"E 18.00'
- L6=S22°35'19"E 2.00'
- L7=S67°24'41"W 18.00'
- L8=N22°35'19"W 2.00'

CURVE INFORMATION

- C1= R=6.50' L=20.42'
- C2= R=6.50' L=20.42'
- C3= R=9.00' L=14.14'
- C4= R=9.00' L=14.14'
- C5= R=9.00' L=14.14'
- C6= R=9.00' L=14.14'

LEGEND

BMP RESERVE AREA

SITE INFO:

N/F John Smith
D.B.
LOC# 20N54-0170

54,635 SQ. FT. / 1.254 Ac.

ZONING INFO:

R-1 ONE ACRE RESIDENCE
43,560 S.F. MINIMUM LOT SIZE
FRONT YARD SETBACK=60'
SIDE YARD STBACK=15'
REAR YARD SETBACK=50'

(3) 01.00'±(2)
E 00°33'00"N

(3) 01.00'±(2)
W 00°33'00"E

EXHIBIT "A"

N88°55'00"W 128.00'
ADAMS (60'W.) DRIVE

INITIAL:

10/1/14

BMP RESERVE

A TRACT OF LAND BEING PART OF THE SOUTHEAST 1/4 OF SECTION 14,
TOWNSHIP 45 NORTH, RANGE 5 EAST,
CITY OF FRONTENAC, ST. LOUIS COUNTY, MISSOURI

Exhibit “B”

MAINTENANCE REQUIREMENTS FOR BIO-RETENTION

PURPOSE

The purpose of the rain garden or bioretention facility is to slow down the flow and reduce the quantity of rainwater run-off reaching the creeks. This is accomplished by capturing the water and allowing it to percolate slowly into the planting soil. Because the soil in Frontenac is generally clayey; infiltration into the native soil is very slow. Therefore, the rain garden has an underdrain system to remove the water once it has passed through the planting soil. The water travels through the soil along the roots of the plants to the underdrain system; therefore, it is important to maintain a healthy stand of vegetation in the rain garden.

WEEDING

As with any garden, bioretention requires weeding of unwanted plant materials. Mulching helps to reduce weed growth and retain moisture in the soil. Weeding shall be accomplished routinely as required.

WATERING

If plants wilt during the heat of the day, but recover in the evening, watering is not necessary. The plants are simply conserving moisture. If they do not recover, watering is indicated. Another good rule of thumb is to stick a pencil or screwdriver about four inches into the soil. If the soil is dry, and the shrubs or trees were planted within the last three years, watering is necessary.

FERTILIZATION

In traditional, intensively cropped landscapes, soil fertility (and especially the level of available nitrogen) is considered the limiting factor to plant growth. By design, however, bioretention facilities are located in areas where nutrients (especially nitrogen) are significantly elevated above natural levels. Therefore, it is unlikely that soil fertility will be the limiting factor in plant growth, and thus fertilization would be unnecessary. Excess fertilization, (besides compromising the facility's pollutant reduction effectiveness) leads to weak plant growth, promotes disease and pest outbreaks, and inhibits soil life. If soil fertility is in doubt, a simple soil test can resolve the question. If fertilization should become necessary, an organic fertilizer will provide nutrients as needed without disrupting soil life.

MULCHING

The mulch materials placed in the facility will decompose and blend with the soil medium over time. Typically, mulch material shall be re-applied once every six months. Only hardwood mulch shall be used as other types may float away. The depth of the mulch layer shall be no more than 3". Mulch applied any deeper than three inches reduces proper oxygen and carbon dioxide cycling between the soil and the atmosphere, and keeps plant roots from making good contact with the soil. The mulch layer provides an important role in the bioretention physical properties for removing heavy metals from the system.

DIVIDING & REPLANTING

The properly designed facility shall thrive and allow planting materials to expand and propagate, eventually becoming overcrowded. If this occurs, perennial plants shall be divided in spring or fall. Plants that do not perform well, or die, shall also be replaced.

TRIMMING AND HARVESTING

Current practice is to leave ornamental grasses and perennial seed heads standing to provide winter interest, wildlife forages, and homes for beneficial insects. Plants should not be cut back until spring when new growth commences, and even then it is only done for neatness, it does not impact growth. Plants may be pinched, pruned, sheared, or dead-headed during the growing season to encourage more flowering, a bushier plant, or a fresh set of leaves. Diseased or damaged plant parts shall be pruned as they occur, and if a plant is pest-infested, then perform cleanup in fall to deny the pest a winter home. Trees and shrubs may be pruned for shape or to maximize fruit production.

STANDING WATER PROBLEMS

Rain gardens are designed to have water standing for up to forty-eight hours. If this period is routinely exceeded, the facility may not be functioning properly. If standing or pooling water occurs forty-eight hours after the rain has stopped, minor corrective action can usually correct it. Pooling water is usually caused by clogging or blockage of the under drain pipes. First the outfall orifice shall be removed and cleaned and the cleanouts shall be checked and the lines snaked. Root kill may be used, if necessary. If these actions do not resolve the problem surface layer or fines obstructing the sand layer between the gravel bed/underdrain may be the issue. The surface blockage problem may be corrected by removing the mulch layer and raking the surface. For blocked sand layer, use lengths of small reinforcing bar (4'-5' #4 rebar) to punch holes every 1' on center. If the soils themselves are causing the problem, punch holes in the soil or optionally, install a "sand window" at least 1 foot wide running vertically to the underdrain system elevation. In a worst-case scenario, the entire facility may need to be reinstalled.

TRASH AND DEBRIS

Runoff flowing into bioretention facilities may carry trash and debris with it, particularly in commercial settings. Trash and debris shall be removed regularly both to ensure that inlets do not become blocked and to keep the area from becoming unsightly.

PET WASTE

Pet waste shall not be left to decay in bioretention facilities because of the danger of disease-causing organisms.

3 INCH AREA ABOVE - LEAVE BLANK (FOR RECORDERS OFFICE USE ONLY)

DOCUMENT TYPE: Maintenance Agreement

DATE OF DOCUMENT:

GRANTOR: Laura Smith, Revocable Trust, dated December 12, 2014
1241 Apex Drive
St. Louis, MO 63131

GRANTEE: City of Frontenac
10555 Clayton Road,
Frontenac, MO 63131

PROPERTY ADDRESS: 1241 Apex Drive, St. Louis, MO 63131

COUNTY LOCATOR #: 20N 530171

CITY/MUNICIPALITY: Frontenac, Missouri

LEGAL DESCRIPTION: Lot 3 of "George," a Subdivision recorded in Plat Book
12, Page 34 of the St. Louis County Missouri Records.

MAINTENANCE AGREEMENT

KNOW ALL MEN BY THESE PRESENTS, that, **Laura Smith Revocable Trust** dated **December 12, 2014**, owner of **1241 Apex Drive** for and in consideration of the approval of site plans and of the issuance of a building permit by the City of Frontenac for new construction in Frontenac Missouri, at **1241 Apex Drive**, and other good and valuable considerations, do hereby agree and promise, as follows:

1. The stormwater management facilities including Best Management Practices (BMP), basins, berms, embankments, french drains, drainage facilities (drains, yard drains, or inlets and connecting pipes) and appurtenances are to be perpetually located within the dimensioned and reserved area, as shown hachured on the Exhibit "A" as attached hereto and made a part hereof.
2. To maintain and operate the stormwater management facilities in conformity with the approved stormwater management design, maintenance and operation plan (attached as Exhibit "B").
3. To maintain all pipes and drains in good working order and maintain all walls, dikes, vegetation, filter media, and any other requisite appurtenances and improvements for the retention and management of stormwater in good repair, in accordance with the design and plans submitted to and approved by the City of Frontenac.
4. That in the event **Laura Smith Revocable Trust**, dated **December 12, 2014**, or its successor in title to said property shall fail to maintain the stormwater management facilities including BMP's, basins, berms, embankments, french drains, drainage facilities, appurtenances and sewer lines in accordance with this agreement the City of Frontenac shall be permitted to enter onto the property and make the repairs and corrections and perform such maintenance as it deems necessary and bill the owners of said property for the services performed. It is further agreed that in the event said bill or charge for the services performed shall not be paid within a period of thirty (30) days said sum shall become a lien on the real property and shall accrue interest at a rate of eight percent (8%) until paid in full.
5. This agreement is irrevocable and shall continue forever or until the City of Frontenac no longer requires this Maintenance Agreement.

IN WITNESS WHEREFORE, the above named owner of said property, have executed these presents this _____ day of _____, 201__.

Laura Smith Revocable Trust, dated December 12, 2014

Laura Smith
Trustee

STATE OF MISSOURI)
) SS.
COUNTY OF ST. LOUIS)

On this _____ day of _____, 2015 before me personally appeared
Laura Smith to me known to be the persons described in and who executed the foregoing
instrument, and acknowledged that they executed the same as their free act and deed.

IN TESTIMONY WHEREOF, I have hereunto set my hand and affixed my notarial seal, the
day and year first above written.

My Commission expires _____

Act performed in the County of St. Louis which adjoins the City of St. Louis.

Notary Public

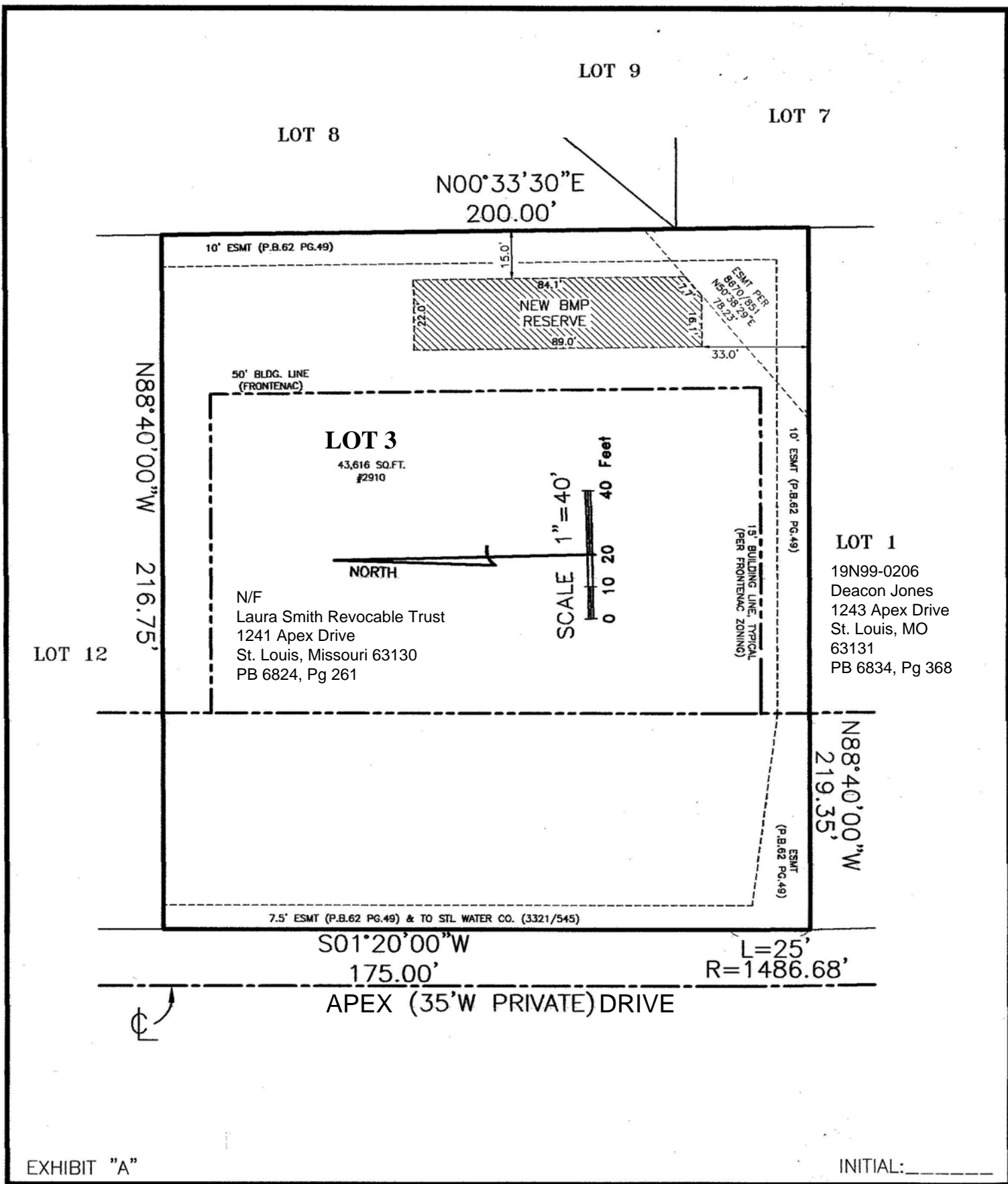

N/F
 Laura Smith Revocable Trust
 1241 Apex Drive
 St. Louis, Missouri 63130
 PB 6824, Pg 261

LOT 1
 19N99-0206
 Deacon Jones
 1243 Apex Drive
 St. Louis, MO
 63131
 PB 6834, Pg 368

EXHIBIT "A"

INITIAL: _____

**LOT 3 OF "GEORGE" PER PLAT
 BOOK 12, PAGE 34, ST. LOUIS
 COUNTY, MISSOURI**

Exhibit “B”

MAINTENANCE REQUIREMENTS FOR ROCK INFILTRATION

PURPOSE

The purpose of the rock infiltration facility is to slow down the flow and reduce the quantity of rainwater run-off reaching the creeks. This is accomplished by capturing the water and allowing it to percolate slowly into the adjacent soil. Because the soil in Frontenac is generally clayey, infiltration into the native soil is very slow. Therefore, the rock infiltration facility has an underdrain system to remove the water once it has reached the clean rock in the underdrain. The outfall orifice is important to ensure that the release of water to the surface or inlet is slowed down and to provide more time for infiltration to take place.

MAINTENANCE

In the first year, the catch basin upstream of the rock infiltration facility should be inspected quarterly and cleaned, if necessary. After the first year, maintenance frequency should be adjusted based on the maintenance required in the first year with a minimum inspection of once per year.

OVERFLOW AT INLET TO ROCK INFILTRATION

The rock infiltration facility is sized to handle 2.5 inches of rain. If more rain than this falls in a 24 hour period, the French drain may over flow at the inlet. If the French drain continuously overflows for smaller rains the connecting pipes or underdrain pipes may be clogged or broken. First the outfall orifice should be cleaned. If this does not resolve the problem, the lines should be snaked. If a portion of the pipe is broken, it should be replaced. If snaking the inflow and outflow lines does not resolve the problem, the line should be replaced. If this does not correct the problem, the facility should be replaced.

RESTRICTIONS

Limestone rock shall not be used in the rock infiltration facility.

DOCUMENT TYPE: MAINTENANCE AGREEMENT

DATE OF DOCUMENT:

GRANTOR: ACE DISTRIBUTORS, INC
128 MICHAEL COURT
ST. LOUIS, MISSOURI 63011

GRANTEE: CITY OF FRONTENAC
10555 CLAYTON ROAD
ST. LOUIS MO. 63131

PROPERTY ADDRESS: 1750 ADAMS DRIVE
FRONTENAC, MO 63131

PROPERTY'S COUNTY LOCATOR NUMBER: 19N65-0095

CITY/ MUNICIPALITY: FRONTENAC, MISSOURI

LEGAL DESCRIPTION: LOT 10 OF MEADOWS SUB
PLAT BOOK 65, PAGES 48 & 49

MAINTENANCE AGREEMENT

KNOW ALL MEN BY THESE PRESENTS, that Ace Distributors, Inc., owners of 1750 Adams Drive, for and in consideration of the approval of site plans and of the issuance of a building permit by the City of Frontenac for new construction in Frontenac, Missouri, at 1750 Adams Drive, Lot 10 of Meadows Sub, PB. 65, PG. 48 & 49, other good and valuable considerations, do hereby agree and promise, as follows:

1. The storm water management facilities include Best Management Practices (BMP), basins, berms, embankments, french drains, drainage facilities (drains, yard drains, or inlets and connection pipes) and appurtenances are to be perpetually located with the dimensioned and reserved area, as shown hachured on the Exhibit "A" as attached hereto and made a part hereof.
2. To maintain and operate the storm water management facilities in conformity with the approved stormwater management design, maintenance and operation plan (attached as Exhibit "B").
3. To maintain all pipes and drains in good working order and maintain all walls, dikes, vegetation, filter media, and any other requisite appurtenances and improvements for the retention and management of storm water in good repair, in accordance with the design and plans submitted to and approved by the City of Frontenac.
4. That in the event Ace Distributors, Inc. or its successor in title to said property shall fail to maintain the storm water management facilities, BMP, basins, drainage facilities, appurtenances and sewer lines in accordance with this agreement, the City of Frontenac shall be permitted to enter onto the property and make the repairs and corrections and perform such maintenance as it deems necessary and bill the owners of said property for the services performed. It is further agreed that in the event said bill or charge for the services performed shall not be paid within a period of thirty (30) days said sum shall become a lien on the real property and shall accrue interest at a rate of eight percent (8%) per annum until paid in full.
5. This agreement is irrevocable and shall continue forever or until the City of Frontenac no longer requires this Maintenance Agreement.

IN WITNESS WHEREFORE, the said Ace Distributors, Inc., Owner of said property, have executed this presents this _____ day of _____, 20____.

BY _____
Signature & Title

BY _____
Print Name & Title

STATE OF MISSOURI)

) SS.

COUNTY OF ST. LOUIS)

On this _____ day of _____, 20____ before me personally appeared _____ to me known to be the person(s) described in and who executed the foregoing instrument, and acknowledged that _____ executed the same as _____ free act and deed.

IN TESTIMONY WHEREOF, I have hereunto set my hand and affixed my notarial seal, the day and year first above written.

My Commission expires _____

Act performed in the County of St. Louis which adjoins the City of St. Louis.

Notary Public

N/F
JOHN & JANE SMITH
15 SMOKIN DR.
ST. LOUIS MO 63131
BOOK 2909 PAGE 32

N/F
JOHN DOE
16 SMOKIN DR.
ST. LOUIS, MO 63131
BOOK 2050 PAGE 41

0 80' 160'

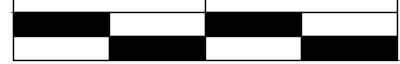

SCALE: 1" = 80'

Spring Creek
PB 65, Pg 48 & 49

N/F
MARY & TOM BROWN
1235 GEORGE LANE
FRONTENAC, MO 63131
BOOK 1051 PAGE 721

N/F
ACE DISTRIBUTORS INC
1750 ADAMS DRIVE
FRONTENAC, MO 63131
PLAT BOOK 33
PAGES 21 & 22

N/F
MARK TRUMBLE
1748 ADAMS DRIVE
FRONTENAC, MO 63131
BOOK 1716 PAGE 2005

BMP RESERVE AREA, AS RECORDED IN THE
ST. LOUIS COUNTY RECORDER OF DEEDS
BK: 21793 PB. 0848, SHALL BE VACATED
PER THIS DOCUMENT

N/F
ANDREW CARTER
1222 GEORGE LANE
FRONTENAC, MO 63131
BOOK 11300 PAGE 207

N21°38'19"W 40.89'(M)
N21°34'20"W 40.89'(R)

N/F
MARY MELROSE
1207 GEORGE LANE
FRONTENAC, MO 63131
BOOK 12175 PAGE 213

N/F
GARY AND SUSAN GEORGE
1695 ADAMS DRIVE
FRONTENAC, MO 3131
BOOK 215 PAGE 39

S88°47'00"E 123.44'(R)
S88°50'59"E 123.44'(M)

N00°40'00"E 197.90'(R)
N00°36'01"E 198.35'(M)

S07°07'19"E 199.70'(R)
S07°07'19"E 199.70'(M)

P.O.C.

S60°42'20"E 59.61'

N35°53'44"E 12.87'

P.O.B.

N00°08'45"E 198.14'(R)
N00°04'24"E 197.69'(M)

S54°06'16"E 17.92'

S35°53'44"W 2.87'

N54°06'16"W 17.92'

R=50.00'(M) 50.00'(R)
L=99.83'(M) 99.80'(R)
CB=S12°14'44"W
CHD=84.06'

S45°05'21"W 230.05'(M)
S45°09'20"W 230.05'(R)

EXHIBIT "A"

BMP RESERVE
LOT 10 OF SPRING CREEK
BOOK 65 PAGE 48 & 49
FRONTENAC, MISSOURI

01/15/2016

EXHIBIT "B"

STORMTANK MAINTENANCE REQUIREMENTS

Purpose

The purpose of the storm tank system is to slow down the flow and reduce the volume of stormwater run-off leaving the property. This is accomplished by capturing a portion of the stormwater run-off and storing it underground in the storm tank system and slowly releasing the volume of water along with allowing it to infiltrate into the soil.

Determining if Maintenance is Required

1. Visual Inspection

A visual inspection of the system should be performed semi-annually looking for any visual deficiency in the system in the form of sedimentation and debris.

Inspect the following:

- a. Man-holes before and/or after the Storm Tank
- b. Inlet and Outlet Pipe
- c. Discharge Area

2. System Operation

- a. Inspect the system while in operation making sure inlets remain open and the system doesn't back-up.

Maintenance Frequency

1. During Construction

Care should be taken to prevent siltation of the system during the construction process.

2. Project Completion

At completion of installation and all project related excavation the system should be flushed to rid the Storm Tank of any construction related debris and/or sedimentation.

3. Regular Maintenance

Maintenance to the system shall be performed based on the findings of the semiannual inspection or decrease in system performance as observed in the system operation.

Maintenance Procedures

1. Determine if maintenance is required. If maintenance is required proceed with the following steps. (If an upstream pretreatment system is being used and requires maintenance, follow maintenance guidelines for that particular product)
2. Using a vacuum pump truck evacuate debris from manholes, inlet and outlet piping and the discharge area.
3. Flush system with clean water (fire hydrant, tanker truck, etc.) forcing debris from the system.
4. Evacuate additional debris as in step 2.
5. Re-flush system
6. Repeat steps 2 and 3 until no additional debris is evident.

Maintenance Precautions

1. Be sure to conform to all safety regulations when performing maintenance.
2. Avoid extreme direct water pressure when flushing the system.

Gutter Protection

The majority of the rainwater is from the roof downspouts. It is vital for the effectiveness of the system to maintain the gutter protection system at all times. Even with the system, gutters should be checked twice per year for leaves and other build up. Any debris collecting in the gutter should be removed promptly. Pipes leading to the retention area should flow freely at all times or be flushed and cleaned as needed.

3 INCH AREA ABOVE - LEAVE BLANK (FOR RECORDERS OFFICE USE ONLY)

DOCUMENT TYPE: **MAINTENANCE AGREEMENT**

DATE OF DOCUMENT:

GRANTOR: **GEORGE STEVENS
16801 CARMONDY COURT
ST. LOUIS, MISSOURI 63131**

GRANTEE: **CITY OF FRONTENAC
10555 CLAYTON ROAD
FRONTENAC, MO 63103**

PROPERTY ADDRESS: **16801-16802 CARMONDY COURT, ST. LOUIS, MO 63131**

COUNTY LOCATOR #: **21M130961**

CITY OF ST. LOUIS PARCEL #: **N/A**

CITY/MUNICIPALITY: **FRONTENAC, MISSOURI**

LEGAL DESCRIPTION: **LOT 'A' AND LOT 'B' OF THE PARCEL SPLIT OF 16801 CARMONDY
COURT, ST. LOUIS COUNTY, CITY OF FRONTENAC, MO**

(SEE EXHIBIT" A")

MAINTENANCE AGREEMENT

KNOW ALL MEN BY THESE PRESENTS, that, **George Stevens (Grantor)** owner of **#16801 & #16802 Carmondy Court** for and in consideration of the approval of sewer plans and of the issuance of a sewer permit by **The City of Frontenac (Grantee)** for storm water management facilities according to plans to be approved by said City for a development known as **#16801 & #16802 Carmondy Court** in Frontenac Missouri, at **Lot 'A' and Lot 'B' of the Parcel Split of 16801 Carmondy Court – 19M605061**, and other good and valuable considerations, do hereby agree and promise, as follows:

1. The storm water management facilities including Best Management Practices (BMP), basins, drainage facilities and appurtenances are to be perpetually located within the dimensioned and reserved area, as shown hachured on the exhibit "A" as attached hereto and made a part hereof.
2. To maintain and operate the storm water management facilities in conformity with the approved storm water management design, maintenance and operation plan (attached as Exhibit "B").
3. To maintain all pipes and drains in good working order and maintain all walls, dikes, vegetation, filter media, and any other requisite appurtenances and improvements for the retention and management of storm water in good repair, in accordance with the design and plans submitted to and approved by The City of Frontenac.
4. That in the event the **Owner(s) of Lot 'A'** and/or **the Owner(s) of Lot 'B'** or their successor in title to said property shall fail to maintain the storm water management facilities, BMP, basins, drainage facilities, appurtenances and sewer lines in accordance with this agreement, the City of Frontenac, shall be permitted to enter onto the property and make the repairs and corrections and perform such maintenance as it deems necessary and bill the owners of said property equally for the services performed. It is further agreed that in the event said bill or charge for the services performed shall not be paid within a period of thirty (30) days said sum shall become a lien on the real property and shall accrue interest at an annual rate of eight percent (8%) until paid in full.
5. Maintenance of the BMP and appurtenances shall be a coordinated effort between the **Owners of Lots A & B**, and each shall grant access to the other as well as their successors and assigns for periodic inspection and maintenance activities. Any disturbance required for maintenance or inspection shall be restored to as good or better condition as it was prior to disturbance.
6. This agreement is irrevocable and shall continue forever or until the City of Frontenac no longer requires this Maintenance Agreement.

16801 & 16802 CARMONDY COURT

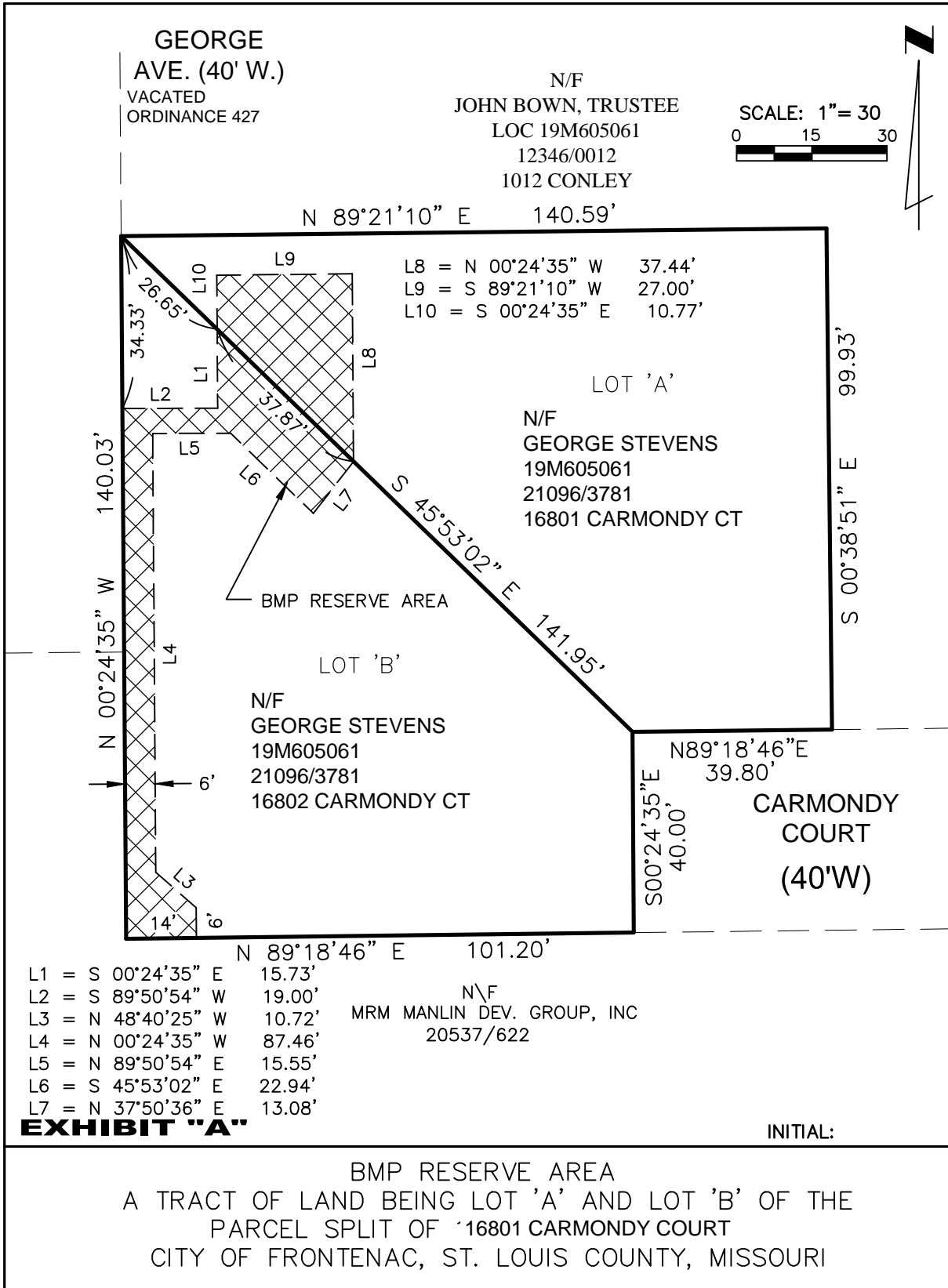

Exhibit "B"

MAINTENANCE REQUIREMENTS FOR STORMWATER STORAGE AREA

PURPOSE

The purpose of the storm water storage area is to slow down the flow and reduce the quantity of rainwater run-off reaching the creeks. This is accomplished by capturing the water and allowing it to percolate slowly into the native soil. Because the soil in Frontenac is generally clayey, infiltration into the native soil is very slow. Therefore, the facility has a drainage system to meter water that does not infiltrate.

STANDING WATER

The storm water storage area is designed to hold water for up to forty-eight hours. If the forty-eight hour period is routinely exceeded maintenance of the system will be required. See Inspection and Maintenance below.

TRASH AND DEBRIS

Runoff flowing into the facilities may carry trash and debris with it. Trash and debris should be removed regularly both to ensure that inlets do not become blocked and to keep the area from becoming unsightly.

PET WASTE

Pet waste should not be left to decay in the facilities due to disease-causing organisms.

INSPECTION AND MAINTENANCE

1. Downspouts and gutter protection/screening is to be maintained at all times. Inspections should be made at least once a month and any debris removed.
2. Drainage Basins should be inspected twice annually and any debris removed.
3. Yard waste and debris should be cleared from the vicinity of the facility on a routine basis to prevent it from blocking the drainage inlets.
4. A visual inspection of the facility should be made twice annually within 24 hours of a heavy rain. In the event of extended periods of standing water (longer than 24 hours), maintenance procedures may need to be initiated.
 - A. First, remove and clean outflow orifice cap to ensure orifice holes are not clogged.
 - B. Verify outflow and underdrain pipes are not blocked by jetting with a garden hose through cleanouts. If blocked, a mechanical cleaning tool and/or service may be required